

Precedent Gas/Electric Packaged Rooftop

Unit Overview - YSC036G3RHB**000000000000000000000000

Application	Unit Size	Supply Fan		External Dimensions (in.)			Operating Weight		EER	IEER/SEER	Elevation
DX cooling, gas heat	3 Ton (036)	Airflow	External Static Pressure	Height	Width	Length	Minimum	Maximum	12.0 EER	14.00	804.00 ft
		1200 cfm	0.500 in H2O	3.41 ft	3.69 ft	5.82 ft	472.0 lb	747.0 lb			

Unit Features

Unit Electrical

Voltage/phase/hertz	208-230/60/3
MCA	20.00 A
MOP	30.00 A



Controls

Unit Controls Microprocessor controls

Cooling Section

Cooling Section		Capacity	
Entering Dry Bulb	80.00 F	Gross Total	37.03 MBh
Entering Wet Bulb	67.00 F	Gross Sensible	29.10 MBh
Ambient Temp	95.00 F	Net Total	36.01 MBh
Leaving Coil Dry Bulb	57.11 F	Net Sensible	28.08 MBh
Leaving Coil Wet Bulb	57.11 F	Fan Motor Heat	1.02 MBh
Leaving Unit Dry Bulb	58.92 F	Refrig Charge-circuit 1	3.2 lb
Leaving Unit Wet Bulb	57.80 F		
Refrigeration System Options			
Leaving Dew Point	57.11 F		

Heating Section

Heat Type	Gas Heat
Heating Stages	2
Output Heating Capacity	97.20 MBh
Output Heating Capacity with Fan	98.47 MBh
Heating EAT	70.00 F
Heating LAT	145.10 F
Heating Temp Rise	75.10 F

Fan Section

Indoor Fan Data		Outdoor Fan Data	
Type	FC Centrifugal	Type	Propeller
Drive Type	Direct	Fan Quantity	1
Evap Fan FLA	5.70 A	Drive Type	Direct
Indoor Fan Performance		Outdoor Fan Performance	
Airflow	1200 cfm	Condenser Fan FLA	1.10 A
Design ESP	0.500 in H2O		
Component SP	0.000 in H2O		
Total SP	0.500 in H2O		
Supply Motor Horsepower	0.750 hp		
Indoor Motor Operating Power	0.41 bhp		
Indoor Motor Power	0.30 kW		
Indoor RPM	939 rpm		

Compressor Section

Power	2.46 kW
Circuit 1 RLA	10.40 A
Circuit 2 RLA	0.00 A

Acoustics								
Sound Path	63 Hz	125 Hz	250 Hz	500 Hz	1 kHz	2 kHz	4 kHz	8 kHz
Ducted Discharge	89 dB	71 dB	69 dB	59 dB	55 dB	51 dB	46 dB	38 dB
Ducted Inlet	89 dB	72 dB	60 dB	53 dB	48 dB	44 dB	42 dB	37 dB
Outdoor Noise	79 dB	85 dB	79 dB	79 dB	77 dB	71 dB	67 dB	58 dB

Note: Ducted Inlet and Ducted Discharge Sound Power Levels are in accordance with AHRI 260.

Note: Outdoor Sound Power Levels are in accordance with AHRI 270.

These cut sheets are for reference only. Stock model numbers may differ. Contact your salesperson for job specific submittals for engineer approval.

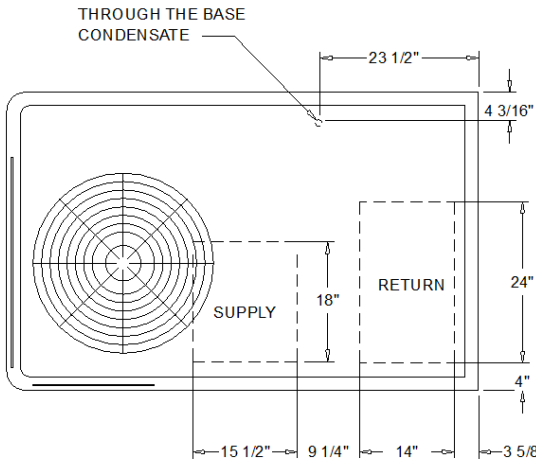
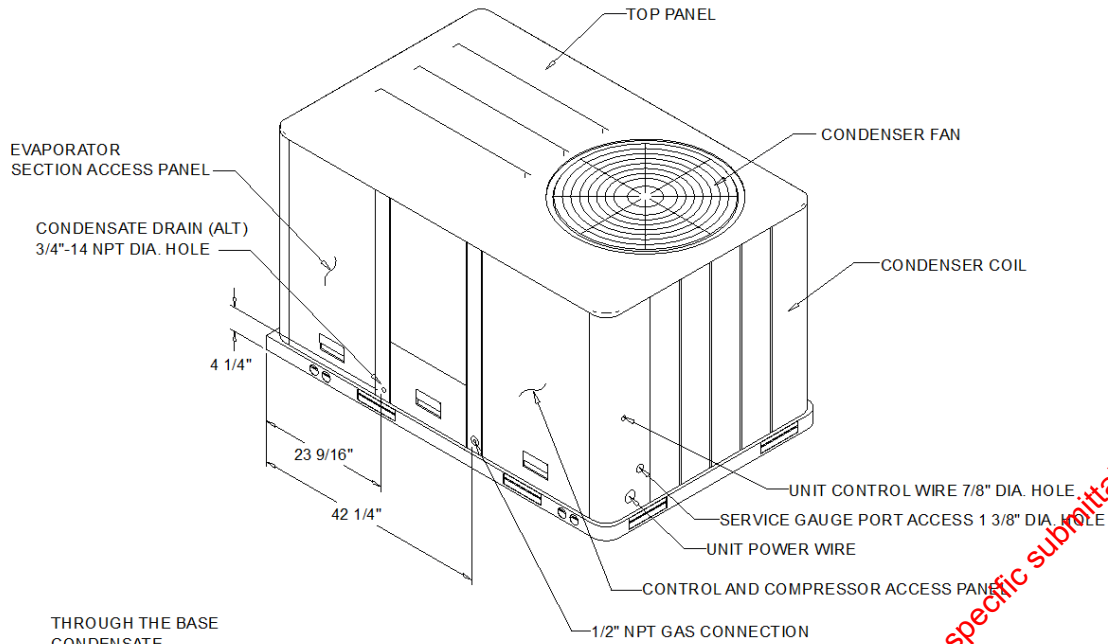

PLAN VIEW UNIT
DIMENSION DRAWING

NOTES:
1. THRU -THE -BASE GAS AND ELECTRICAL IS NOT STANDARD ON ALL UNITS.
2. VERIFY WEIGHT, CONNECTIONS AND ALL DIMENSION WITH INSTALLER DOCUMENTS BEFORE INSTALLATION

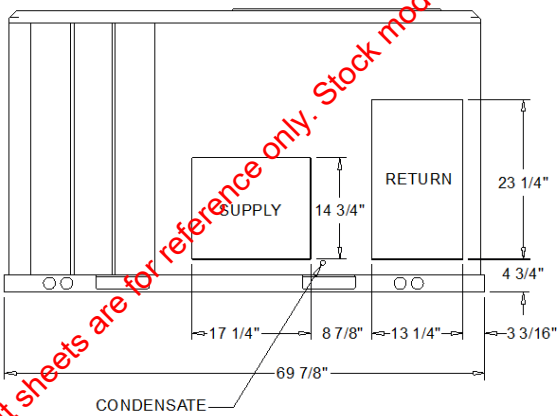

PACKAGED GAS / ELECTRICAL
DIMENSION DRAWING

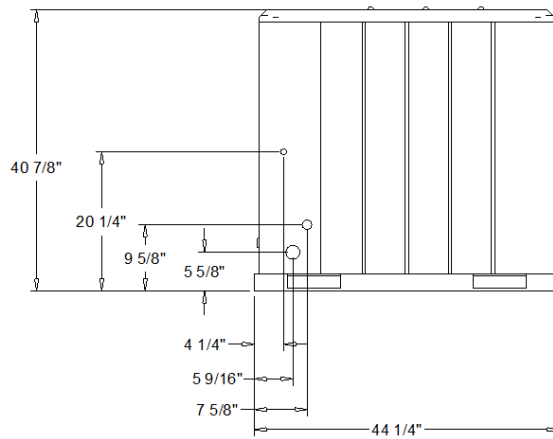

HORIZONTAL
AIR FLOW

These cut sheets are for reference only. Stock model numbers may differ. Contact your salesperson for job specific submittals for engineer approval.

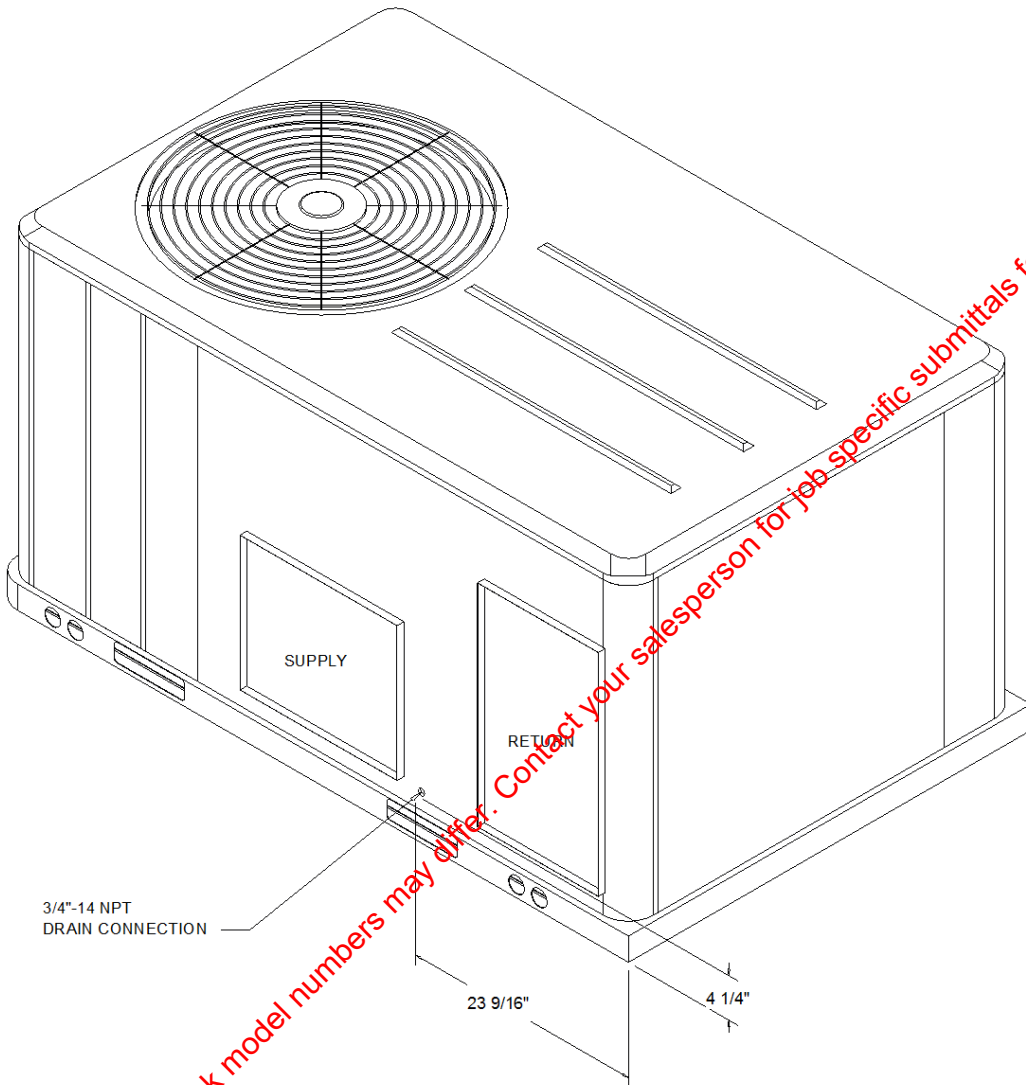

ISOMETRIC-PACKAGED COOLING

These cut sheets are for reference only. Stock model numbers may differ. Contact your salesperson for job specific submittals for engineer approval.

ELECTRICAL / GENERAL DATA

GENERAL (2)(4)(6) Model: YSC036G Oversized Motor Unit Operating Voltage: 187-253 MCA: N/A Unit Primary Voltage: 208 MFS: N/A Unit Secondary Voltage: 230 MCB: N/A Unit Hertz: 60 Unit Phase: 3 EER/SEER 12.0/14.0 Standard Motor MCA: 20.0 MCA: N/A MFS: 30.0 MFS: N/A MCB: 30.0 MCB: N/A		HEATING PERFORMANCE HEATING - GENERAL DATA Heating Model: High Heating Input (BTU): 120,000/84,000 Heating Output (BTU): 97,200/68,040 No. Burners: 4 No. Stages: 2 Gas Inlet Pressure Natural Gas (Min/Mix): 4 1/2"/14" LP (Min/Max) 11"/14" Gas Pipe Connection Size: 1/2"	
INDOOR MOTOR Standard Motor Oversized Motor Field Installed Oversized Motor Number: 1 Number: N/A Number: Horsepower: 0.75 Horsepower: N/A Horsepower: Motor Speed (RPM): -- Motor Speed (RPM): N/A Motor Speed (RPM): Phase: 1 Phase: N/A Phase: Full Load Amps: 5.7 Full Load Amps: N/A Full Load Amps: Locked Rotor Amps: -- Locked Rotor Amps: N/A Locked Rotor Amps:			
COMPRESSOR Circuit 1/2 Number: 1 Horsepower: 2.8 Phase: 3 Rated Load Amps: 10.4 Locked Rotor Amps: 73.0		OUTDOOR MOTOR Number: 1 Horsepower: 0.25 Motor Speed (RPM): 1100 Phase: 3 Full Load Amps: 1.6 Locked Rotor Amps: 1.6	
POWER EXHAUST ACCESSORY (3,7) (Field Installed Power Exhaust) Phase: N/A Horsepower: N/A Motor Speed (RPM): N/A Full Load Amps: N/A Locked Rotor Amps: N/A		FILTERS Type: Throwaway Furnished: Yes Number: 2 Recommended: 20"x35"x2"	
REFRIGERANT (2) Type Factory Charge Circuit #1: 3.2 lb Circuit #2: N/A			

NOTES:

1. Maximum (HACR) Circuit Breaker sizing is for installations in the United States only.
2. Refrigerant charge is an approximate value. For a more precise value, see unit nameplate and service instructions.
3. Value does not include Power Exhaust Accessory.
4. Value includes oversized motor.
5. Value does not include Power Exhaust Accessory.
6. EER is rated at AHRI conditions and in accordance with DOE test procedures.
7. Installation of this power exhaust kit will affect unit level MCA and could affect MOP sizing having a direct impact on existing field wiring and unit protection devices. The change in MCA/MOP is the sole responsibility of the field installing party. Trane will not issue new nameplates as a result of this power exhaust accessory installation. FLA of the power exhaust kit option must be added to the MCA of the unit for building supply conductor sizing determination.

These cut sheets are for reference only. Stock model numbers may differ. Contact your salesperson for job specific submittals for engineer approval.

INSTALLED ACCESSORIES NET WEIGHT DATA

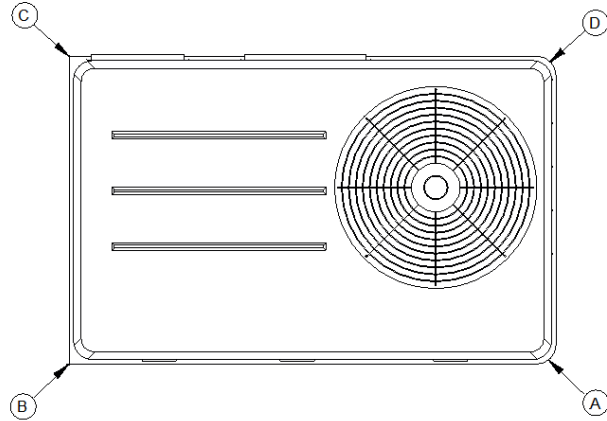

PACKAGED GAS / ELECTRICAL
CORNER WEIGHT

ACCESSORY		WEIGHTS			
ECONOMIZER					
MOTORIZED OUTSIDE AIR DAMPER					
MANUAL OUTSIDE AIR DAMPER					
BAROMETRIC RELIEF					
OVERSIZED MOTOR					
BELT DRIVE MOTOR					
POWER EXHAUST					
THROUGH THE BASE ELECTRICAL/GAS (FIOPS)					
UNIT MOUNTED CIRCUIT BREAKER (FIOPS)					
UNIT MOUNTED DISCONNECT (FIOPS)					
POWERED CONVENIENCE OUTLET (FIOPS)					
HINGED DOORS (FIOPS)					
HAIL GUARD					
SMOKE DETECTOR, SUPPLY / RETURN					
NOVAR CONTROL					
STAINLESS STEEL HEAT EXCHANGER					
REHEAT					
ROOF CURB					
BASIC UNIT WEIGHTS		CORNER WEIGHTS		CENTER OF GRAVITY	
SHIPPING	NET	(A)	(C)	(E) LENGHT	(F) WIDTH
577.0 lb	472.0 lb	(B) 193.0 lb	(D) 45.0 lb	33"	9"

NOTE:

1. All weights are approximate.
 2. Weights for options that are not list refer to Installation guide.
 3. Actual weight are listed on the unit nameplate.
 4. Refer to unit nameplate and installation guide for weights before scheduling transportation and installation of unit.
- The weight shown represents the typical unit operating weight for the configuration selected. Estimated at +/- 10 % of the nameplate weight.
6. Verify weight, connection, and all dimension with installer documents before installation.
 7. Corner weights are given for information only.
 8. Net/Shipping weight of optional accessories should be added to unit weight when ordering factory or field installed accessories.

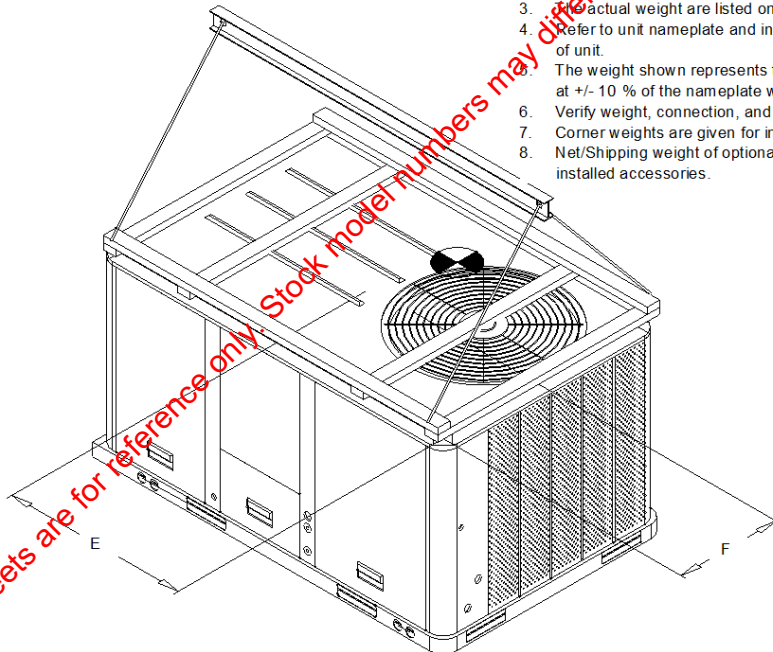

PACKAGED GAS / ELECTRICAL
RIGGING AND CENTER OF GRAVITY

These cut sheets are for reference only. Stock model numbers may differ. Contact your salesperson for job specific submittals for engineer approval.

CLEARANCE FROM TOP OF UNIT 72"

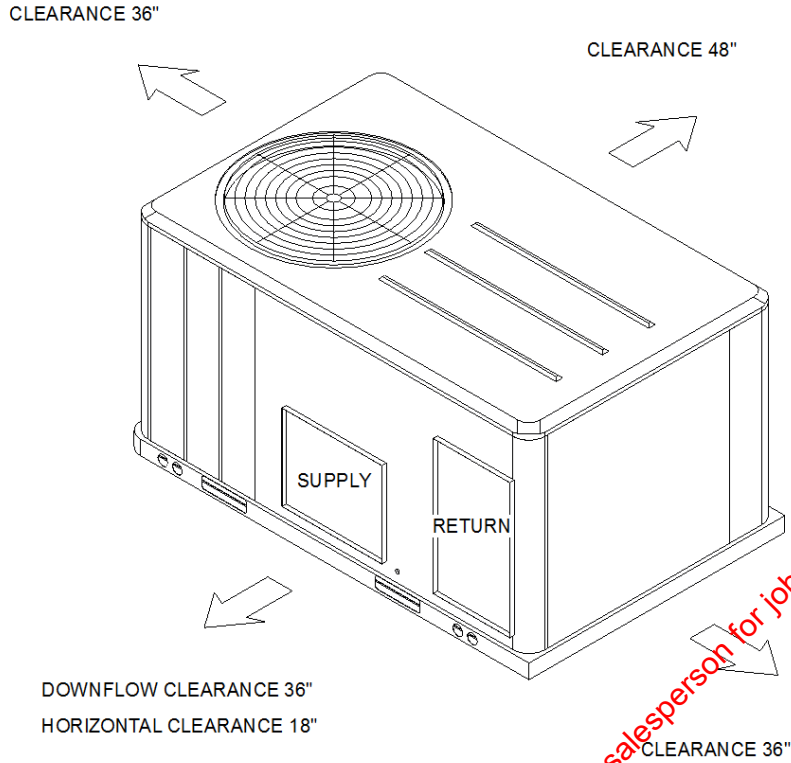

PACKAGED GAS / ELECTRIC
CLEARANCE

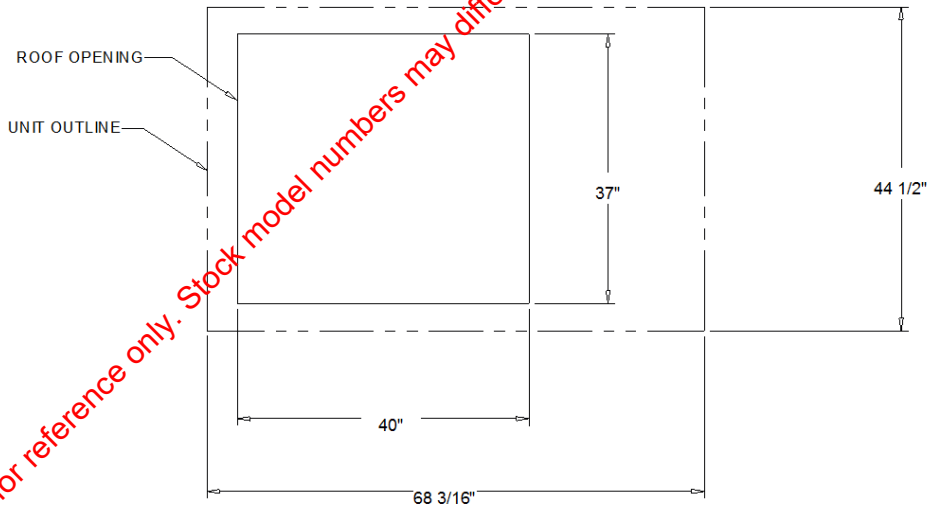

PACKAGED GAS / ELECTRIC
DOWNFLOW TYPICAL ROOF OPENING

These cut sheets are for reference only. Stock model numbers may differ. Contact your salesperson for job specific submittals for engineer approval.

General

The units shall be convertible airflow. The operating range shall be between 115°F and 0°F in cooling as standard from the factory for units with microprocessor controls. Operating range for units with electromechanical controls shall be between 115°F and 40°F. Cooling performance shall be rated in accordance with ARI testing procedures. All units shall be factory assembled, internally wired, fully charged with R-410A, and 100 percent run tested to check cooling operation, fan and blower rotation, and control sequence before leaving the factory. Wiring internal to the unit shall be colored and numbered for simplified identification. Units shall be cULus listed and labeled, classified in accordance for Central Cooling Air Conditioners.

Casing

Unit casing shall be constructed of zinc coated, heavy gauge, galvanized steel. Exterior surfaces shall be cleaned, phosphatized, and finished with a weather-resistant baked enamel finish. Unit's surface shall be tested 672 hours in a salt spray test in compliance with ASTM B117. Cabinet construction shall allow for all maintenance on one side of the unit. Service panels shall have lifting handles and be removed and reinstalled by removing two fasteners while providing a water and air tight seal. All exposed vertical panels and top covers in the indoor air section shall be insulated with a cleanable foil-faced, fire-retardant permanent, odorless glass fiber material. The base of the unit shall be insulated with 1/8", foil-faced, closed-cell insulation. All insulation edges shall be either captured or sealed. The unit's base pan shall have no penetrations within the perimeter of the curb other than the raised 1 1/8" high downflow supply/return openings to provide an added water integrity precaution, if the condensate drain backs up. The base of the unit shall have provisions for forklift and crane lifting, with forklift capabilities on three sides of the unit.

Unit Top

The top cover shall be one piece construction or, where seams exist, it shall be double-hemmed and gasket-sealed. The ribbed top adds extra strength and enhances water removal from unit top.

Filters

Throwaway filters shall be standard on all units. Optional 2-inch MERV 8 and MERV 13 filters shall also be available.

Compressors

All units shall have direct-drive, hermetic, scroll type compressors with centrifugal type oil pumps. Motor shall be suction gas-cooled and shall have a voltage utilization range of plus or minus 10 percent of unit nameplate voltage. Internal overloads shall be provided with the scroll compressors.

Dual compressors are outstanding for humidity control, light load cooling conditions and system back-up applications. Dual compressors are available on 7½-10 ton models and allow for efficient cooling utilizing 3-stages of compressor operation for all high efficiency models.

Indoor Fan

The following units shall be equipped with a direct drive plenum fan design (T/YSC120F, T/YHC074F, T/YHC092F, T/YHC102F, 120F). Plenum fan design shall include a backward-curved fan wheel along with an external rotor direct drive variable speed indoor motor. All plenum fan designs will have a variable speed adjustment potentiometer located in the control box.

3 to 5 ton units (high efficiency 3-phase with optional motor) are belt driven, FC centrifugal fans with adjustable motor sheaves. 3 to 5 ton units (standard and high efficiency 3-phase) have multispeed, direct drive motors. All 6 to 8½ ton units (standard efficiency) shall have belt drive motors with an adjustable idler-arm assembly for quick-adjustment to fan belts and motor sheaves. All motors shall be thermally protected. All 10 tons, 6 ton (074), 7½ to 8½ (high efficiency) units have variable speed direct drive motors. All indoor fan motors meet the U.S. Energy Policy Act of 1992 (EPACT).

Outdoor Fans

The outdoor fan shall be direct-drive, statically and dynamically balanced, draw-through in the vertical discharge position. The fan motor shall be permanently lubricated and shall have built-in thermal overload protection.

Evaporator and Condenser Coils

Internally finned, 5/16" copper tubes mechanically bonded to a configured aluminum plate fin shall be standard. Evaporator coils are standard for all 3 to 10 ton standard efficiency models. Microchannel condenser coils are standard for all 3 to 10 ton standard efficiency models and 4, 5, 6, 7.5, 8.5 ton high efficiency models. The microchannel type condenser coil is not offered on the 4 and 5 ton dehumidification model. Due to flat streamlined tubes with small ports, and metallurgical tube-to-fin bond, microchannel coil has better heat transfer performance. Microchannel condenser coil can reduce system refrigerant charge by up to 50% because of smaller internal volume, which leads to better compressor reliability. Compact all-aluminum microchannel coils also help to reduce the unit weight. These all aluminum coils are recyclable. Galvanic corrosion is also minimized due to all aluminum construction. Strong aluminum brazed structure provides better fin protection. In addition, flat streamlined tubes also make microchannel coils more dust resistant and easier to clean. Coils shall be leak tested at the factory to ensure the pressure integrity. The evaporator coil and condenser coil shall be leak tested to 600 psig. The assembled unit shall be leak tested to 465 psig. The condenser coil shall have a patent pending 1+1+1 hybrid coil designed with slight gaps for ease of cleaning. A plastic, dual-sloped, removable and reversible condensate drain pan with through-the-base condensate drain is standard.

Controls

Unit shall be completely factory-wired with necessary controls and contactor pressure lugs or terminal block for power wiring. Unit shall provide an external location for mounting a fused disconnect device. A choice of microprocessor or electromechanical controls shall be available. Microprocessor controls provide for all 24V control functions. The resident control algorithms shall make all heating, cooling, and/or ventilating decisions in response to electronic signals from sensors measuring indoor and outdoor temperatures. The control algorithm maintains accurate temperature control, minimizes drift from set point, and provides better building comfort. A centralized microprocessor shall provide anti-short cycle timing and time delay between compressors to provide a higher level of machine protection. 24-volt electromechanical control circuit shall include control transformer and contactor

High Pressure Control

All units include High Pressure Cutout as standard.

Phase monitor

Phase monitor shall provide 100% protection for motors and compressors against problems caused by phase loss, phase imbalance, and phase reversal. Phase monitor is equipped with an LED that provides an ON or FAULT indicator. There are no field adjustments. The module will automatically reset from a fault condition.

Refrigerant Circuits

Each refrigerant circuit offer thermal expansion valve as standard. Service pressure ports, and refrigerant line filter driers are factory-installed as standard. An area shall be provided for replacement suction line driers.

Gas Heating Section

The heating section shall have a progressive tubular heat exchanger design using stainless steel burners and corrosion resistant steel throughout. An induced draft combustion blower shall be used to pull the combustion products through the firing tubes. The heater shall use a direct spark ignition (DSI) system. On initial call for heat, the combustion blower shall purge the heat exchanger for 20 seconds before ignition. After three unsuccessful ignition attempts, the entire heating system shall be locked out until manually reset at the thermostat/zone sensor. Units shall be suitable for use with natural gas or propane (field-installed kit) and also comply with the California requirement for low NOx emissions (Gas/Electric Only).

ATTENTION

For installation in SCAQMD only: This furnace does not meet the SCAQMD Rule 1111 14 ng/J NOx emission limit, and thus is subject to a mitigation fee of up to \$450. This furnace is not eligible for the Clean Air Furnace Rebate Program: www.CleanAirFurnaceRebate.com.

Sequence of Operation (if applied in a SINGLE-ZONE CONSTANT-VOLUME SYSTEM or a CHANGEOVER BYPASS SYSTEM)

B. SINGLE-ZONE CONSTANT-VOLUME SYSTEM

1. OCCUPIED HEAT/COOL:

The RTU shall operate the supply fan continuously and modulate (or cycle) compressors, modulate (or stage) heat, and/or enable airside economizing to maintain zone temperature at setpoint. The OA damper shall open to bring in the required amount of ventilation.

2. MORNING WARM-UP/PRE-COOL:

The RTU shall operate the supply fan and modulate (or cycle) compressors or modulate (or stage) heat to raise/lower zone temperature to its occupied setpoint. The OA damper shall remain closed, unless economizing.

D. CHANGEOVER BYPASS SYSTEM

1. OCCUPIED HEAT/COOL:

Each VAV terminal shall use pressure-independent control, with airflow measurement, to vary primary airflow to maintain zone temperature at its occupied setpoint. The RTU shall modulate the bypass damper to maintain duct static pressure at setpoint and modulate (or cycle) compressors, modulate (or stage) heat, and/or enable airside economizing based on current zone cooling/heating demands. The OA damper shall open to bring in the required amount of ventilation.

2. MORNING WARM-UP/PRE-COOL:

Each VAV terminal unit shall vary primary airflow to raise/lower zone temperature to its occupied setpoint. The RTU shall modulate the bypass damper to maintain duct static pressure at setpoint and modulate (or cycle) compressors or modulate (or stage) heat based on current zone cooling/heating demands. The OA damper shall remain closed, unless economizing.

3. COOLING/HEATING CHANGEOVER LOGIC:

The System Controller shall determine the overall system cooling/heating mode based on "voting" from each zone. When the majority of zones require cooling, the RTU shall operate in cooling mode and any zone that requires heating shall reduce primary airflow to minimum. When the majority of zones require heating, the RTU shall operate in heating mode and any zone that requires cooling shall reduce primary airflow to minimum.

These cut sheets are for reference only. Stock model numbers may differ. Contact your sales representative for job specific details for engineer approval.